

REFERENCE MANUAL

AO[®] Series 2000 Student Microscopes

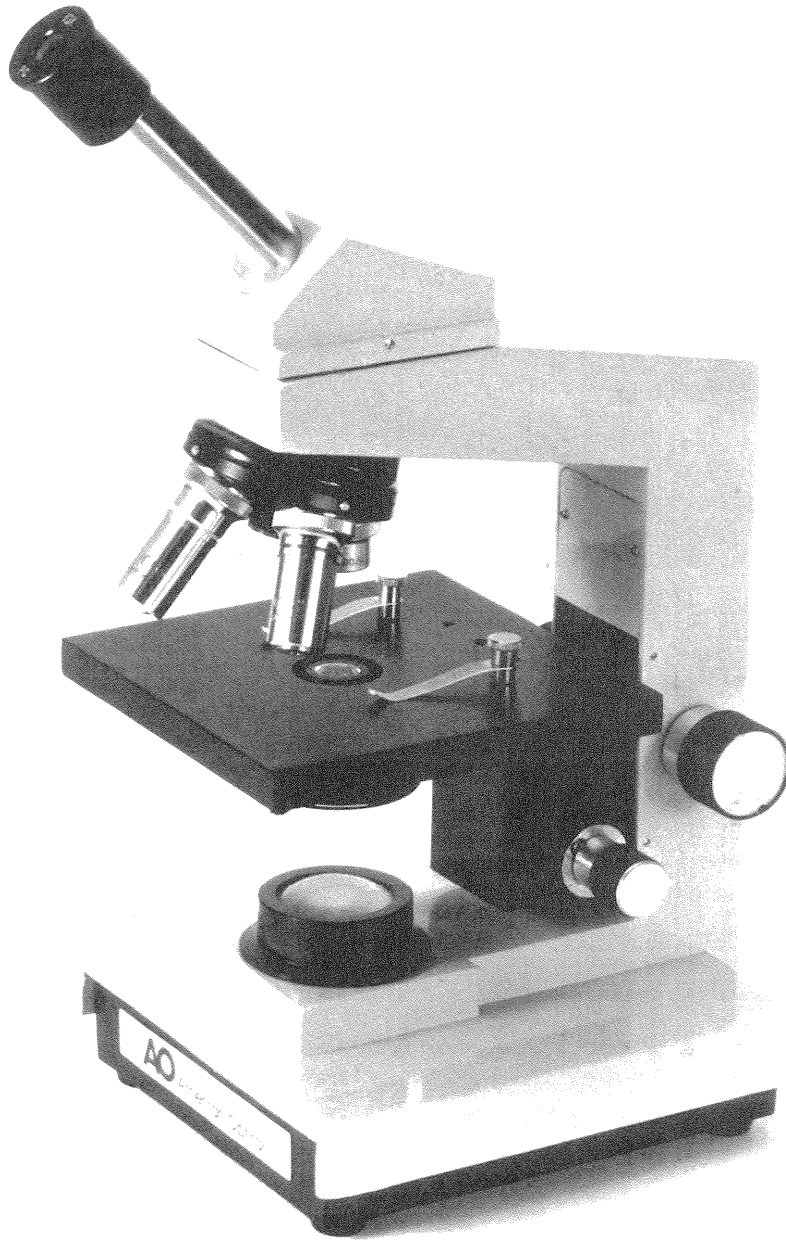

PRICE: \$1.00

AO[®] American Optical

SCIENTIFIC INSTRUMENTS
BOX 123, BUFFALO, NY 14240

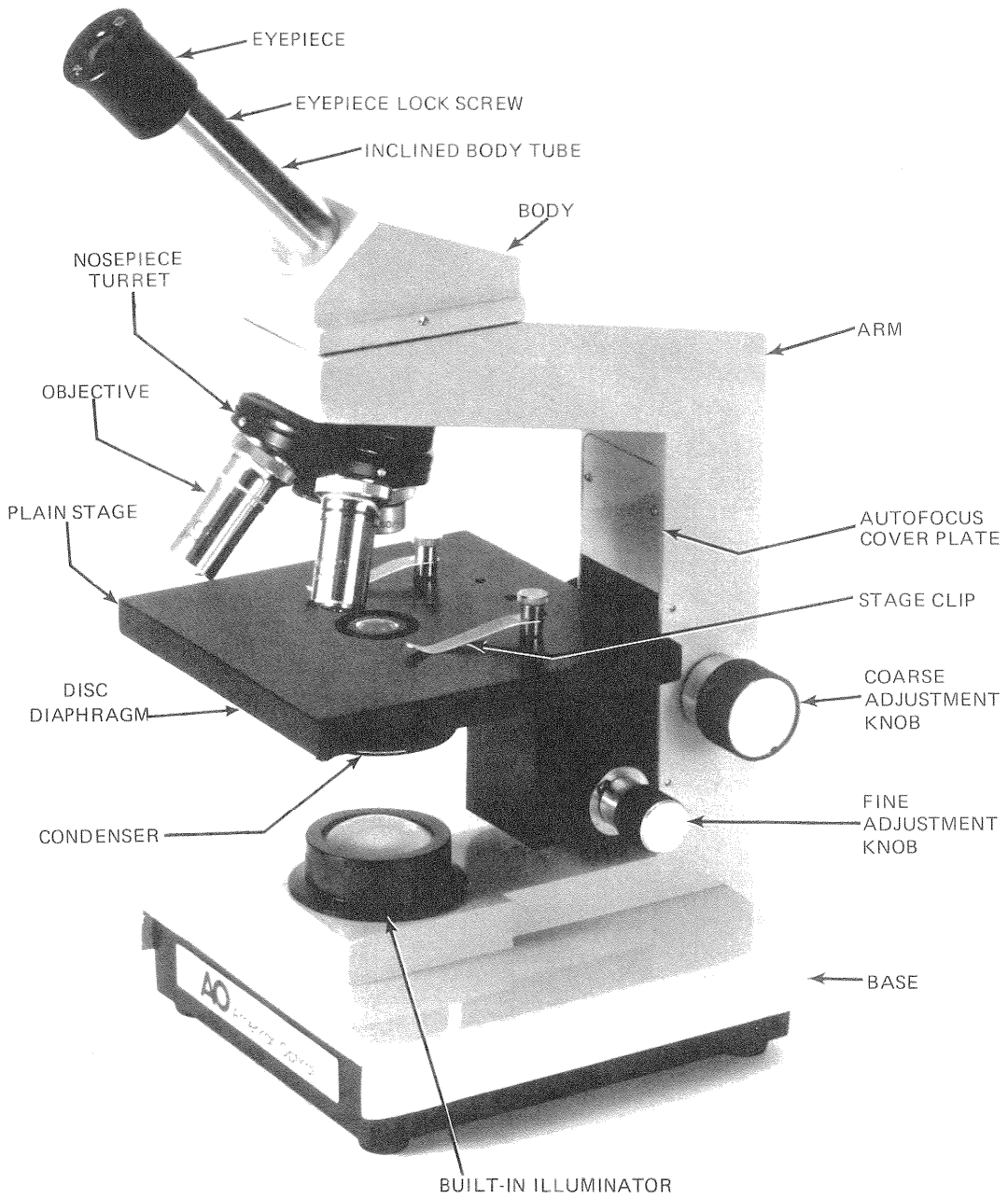

OPERATION

Instrument comes completely assembled.

1. Focusing

- a. Rotate Coarse Adjustment Knob to lower objective as close as possible to the specimen.
- b. While viewing through eyepiece, rotate Coarse Adjustment Knob in opposite direction until specimen is in focus.
- c. Rotate Fine Adjustment Knob until specimen detail is in sharpest possible focus.

2. Adjusting Autofocus Stop

This built-in feature prevents objectives from being racked down onto slide, avoiding possible damage to both.

- a. Remove cover plate.
- b. Loosen nut with wrench.
- c. Adjust thumbscrew up or down.
- d. Retighten nut.
- e. Replace cover plate.

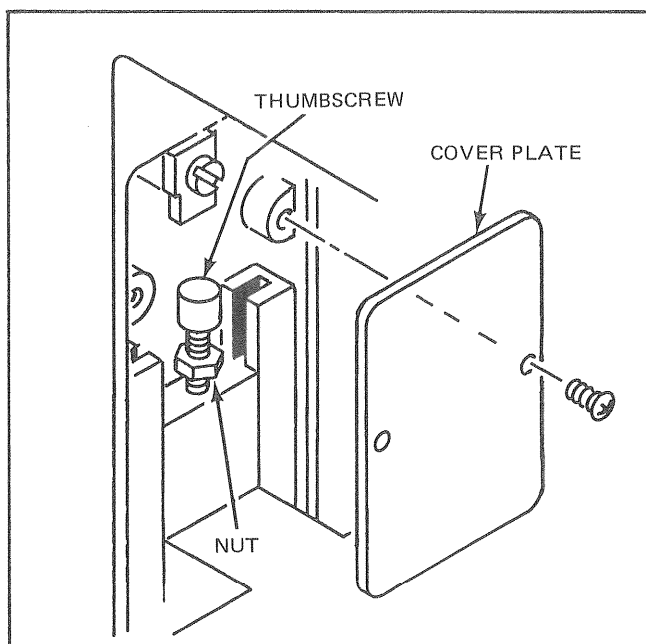

3. Adjust Condenser Control Knob until sharpest image contrast is reached.

Body

Body is completely rotatable 360° by hand turning.

GENERAL CARE

1. Microscope Stand and Mechanical Parts

- a. Use both hands when carrying the instrument. One, firmly grasping the arm of the microscope; the other, beneath the base. Avoid sudden jars.
- b. The finish is tough and durable . . . resists chipping, staining and corrosive action of common laboratory chemicals. Clean with very mild soap or detergent solution when required. Other metal surfaces may be similarly cleaned. Dampen, do not soak, your lint-free cloth for this purpose. Finally, wipe off thoroughly and buff with dry lint-free cloth.

Optical Parts Cleaning

Do not clean optical parts unnecessarily. If the specimen image seems to have deteriorated and lacks definition:

1. Check quality of specimen preparation by viewing a different area of the slide, or insert a slide of known results, or turn nosepiece to another objective.
2. If the image quality is improved by the latter, but not the former, cleaning of bottom lens of objective is indicated.
3. Blurred specks in the field are generally caused by dust or smears on the eyepiece or cover glass. If the specks move when eyepiece is rotated, clean top lens of the eyepiece. If the specks move when slide is moved slightly, clean cover glass.

GLASS SURFACES SHOULD NEVER BE TOUCHED WITH THE FINGERS. If a glass surface does require cleaning:

1. Dust it off with clean camel's hair brush or blow it off with ear syringe.

2. Wipe off with clean, soft cloth or lens paper slightly moistened with distilled water . . . and carefully wipe dry in a circular motion.
3. If film persists, use mild soap or detergent or xylene. Never supersaturate cloth or lens paper. This could cause internal seepage.
4. Recessed lenses of objectives can best be cleaned at the outer periphery by using a moistened cotton swab (Q-Tip) with a slight twirling motion. Lens paper or soft cloth wound around a soft wooden stick can serve the same purpose.

Objectives and eyepieces should not be taken apart.

CAUTION: REMOVE PLUG FROM ELECTRICAL OUTLET AND ALLOW BULB TO COOL PRIOR TO BULB REPLACEMENT.

Bulb Replacement

1. Remove center base plate.
2. Twist bulb 1/4 turn and remove.
3. Replace bulb.

Replacement Bulb: A.O. No. 629 (GE 15T7DC)

WARRANTY

For 1 year from the date of purchase by the end-user, American Optical will repair or replace, at its option, this product for shipping charges only, if defective in workmanship or material. Contact your ordering dealer for instructions and furnish original invoice information.

This warranty does not apply if the product has been misused in any way, or has been altered or repaired by other than an authorized American Optical Representative.

THIS WARRANTY IS IN LIEU OF ALL OTHER WARRANTIES IMPLIED OR EXPRESSED. ALL IMPLIED WARRANTIES OF MERCHANTABILITY OR FITNESS FOR A PARTICULAR PURPOSE ARE HEREBY DISCLAIMED.

No one is authorized to make any obligations for American Optical not in accordance with the above. American Optical shall under no circumstances be liable for special, incidental or consequential damages from any negligence, breach of warranty, strict liability or any other theory arising out of or relating to the design, manufacture, use or handling of the product.

CLAIMS AND RETURNS

If discrepancies are discovered, an immediate report should be made to the customer's ordering point referring to the packing list number. All packing should be carefully examined to insure that no small items are overlooked. Claims for loss or damage in transit should be made directly to the transportation company.

If, upon delivery, the outside of the packing case shows evidence of rough handling or damage, the transportation company's agent should be requested to make a "Received in Bad Order" notation on the delivery receipt. If there is no exterior evidence of rough handling upon delivery, but concealed damage is evident upon unpacking the shipment within 48 hours of delivery, the transportation company should be requested to make out a "Bad Order" report. This procedure is necessary in order to maintain the right of recovery from the carrier.

Customers are requested to contact their ordering dealer for permission to return any goods for any reason. The request should indicate the date and number of the invoice, or packing list. If arrangements are made for a return, the material should be plainly tagged with the customer's name and address, carefully packed and shipped PREPAID.

PRODUCT CHANGES

American Optical Corporation reserves the right to change designs or to make additions to or improvements in its products without imposing any obligation on itself to add such to products previously manufactured.

The equipment supplied may not agree in all details with our description or illustrations because instruments are subject to modification and improvement.

SERVICE

Repairs should be performed only by qualified service personnel. Complete repair facilities are available at many AO authorized dealers, and AO Technical Service Centers in Buffalo, N.Y., Rosemont, Ill., No. Hollywood, Calif., Edison, N.J., and Dallas, Texas.