

The LEICA GALEN™ III Phase Kit

Image Formation by Phase Contrast

An annular aperture in the diaphragm, placed in the focal plane of the substage condenser, controls the illumination on the object. The aperture is imaged by the condenser and objective at the rear focal plane, or at exit pupil of the objective. A phase shifting element, or phase plate, is placed in the plane.

Light, shown by the solid lines, passes through the phase altering pattern, acquires a one-quarter wave length of green light advance over that diffracted by the object structure (broken lines) and passes through that region of the phase plate not covered by the altering pattern. The resultant interference effects of the two portions of light form the final image. Altered phase relations in the illuminating rays, induced by otherwise invisible elements in the specimen, are translated into brightness differences by the phase altering plate. (The eyepiece is not shown in this diagram.)

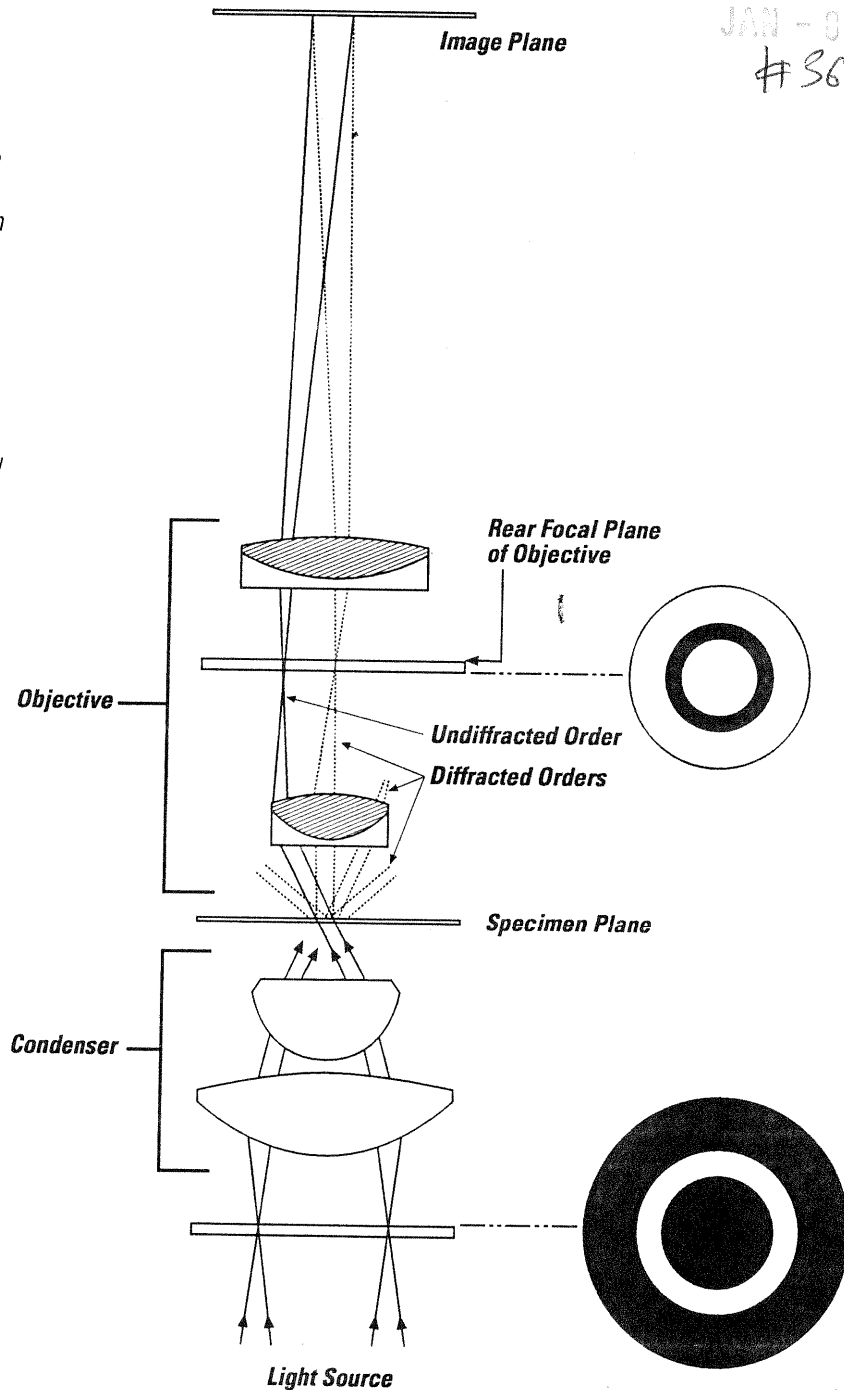

SENT BY FAX

JAN - 8 1983

#366

Instruction Manual

Leica

The LEICA GALEN™ III Phase Kit

Instruction Manual

1.0 Introduction

Before beginning, please check to make sure that you have the following equipment:

Part No. Description

317549	10X Planachromatic Phase Objective
317550	20X Planachromatic Phase Objective
317551	40X Planachromatic Phase Objective
317552	100X Planachromatic Phase Objective
317553	Turret Condenser with Phase Inserts
317554	Centering Telescope
317555	Green Filter

- Small screwdriver (slot variety, to fit the locking screw in the condenser mount)
- A prepared slide with a clear area

2.0 Installing The Phase Kit

1. Using the coarse focus control, lower the stage as far as it will go. Unscrew the normal brightfield objectives from the LEICA GALEN III nosepiece and replace them with the black barreled Phase objectives found in the LEICA GALEN III phase kit.

2. Using the condenser focus knob, raise the condenser as far as it will go. While supporting the bottom of the condenser, loosen the locking screw which holds it in place. Gently slide the condenser out of its mount.

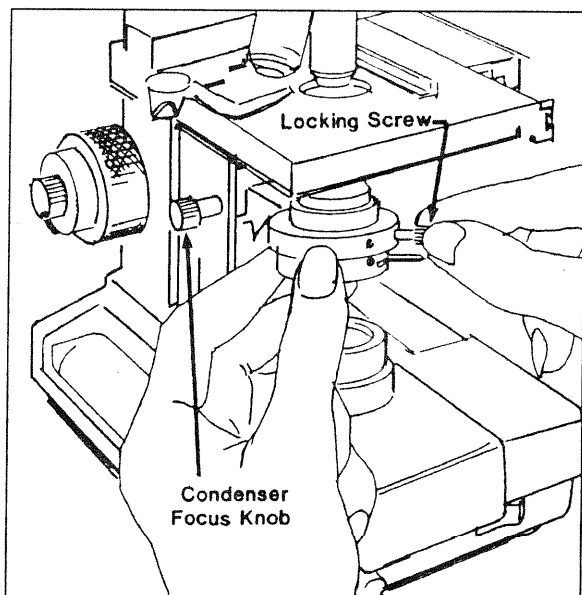

Figure 1

3. Slide the Phase condenser into the condenser mount. (If there is not enough clearance, gently use the coarse focus to raise the stage, taking care not to hit the objectives). If the Phase condenser is turret version, make sure that the silver centering screws point toward 4 o'clock and 7 o'clock. Using a small screw driver, tighten the locking screw. Make sure that the screw is tight enough so that the upper portion of the condenser does not rotate in its mount.

3.0 Alignment

1. Rotate the nosepiece so that the 10X phase objective is in position.

2. Using the knurled ring that forms the bottom half of the phase turret, rotate the condenser insert until the "0" faces front and clicks into position.

3. Using the switch on the front panel of the LEICA GALEN III, turn on the light. Illumination can be adjusted using the slider on the right side of the microscope, in the base.

4. Place a specimen slide in the holder on the stage and, using the coaxial stage controls, move the slide so that part of the specimen is over the light path.

5. Using the condenser focus control, position the condenser by about the thickness of a sheet of paper below the slide.

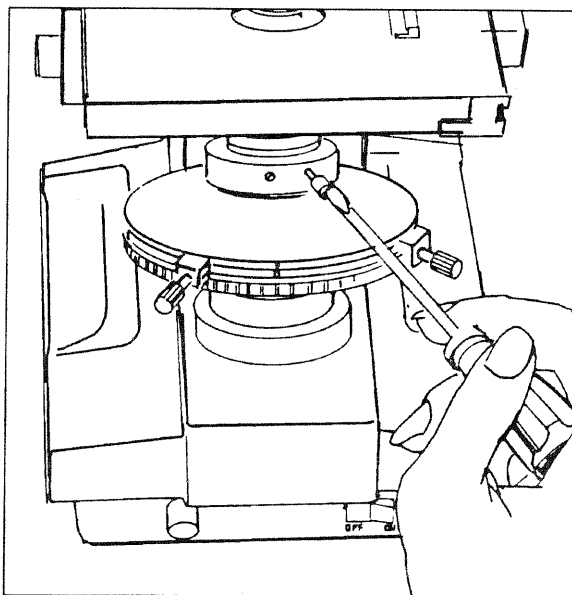

Figure 2

6. Using the coarse and fine focus controls, bring the image of the specimen into focus. Once the image is in focus, move the specimen to a clear area.
7. Rotate the insert in the condenser until the "10" faces forward and clicks into place.
8. Remove one of the eyepieces and replace it with the centering telescope from the Phase Kit. (Since the telescope focuses on a different plane within the microscope than the eyepieces do, do not try to look through both the eyepiece and the telescope at the same time). Loosen the small locking screw on the telescope and, while looking through the telescope, raise or lower the inner tube until the image is sharply focused. You should see two rings of the same size, one slightly darker than the other. Tighten the locking screw. If one of the rings is in focus but the other is not, use the telescope focusing mechanism to sharply image the darker ring then use the condenser focus control to image the brighter ring.
9. Loosen the two centering screws in the condenser and, while viewing through the telescope, slide the locking screws back and forth in their mount until the light ring matches the darker ring. When the rings overlay each other exactly, tighten the screws.
10. Remove the telescope and replace it with the conventional eyepiece.
11. Place the green filter from the Phase kit over the light port in the base of the microscope.

As you move from one objective to another, the alignment may need to be adjusted slightly. With a little practice, the procedure will flow quickly and easily.

You should now have a clean, high quality phase image. If not, check the alignment procedure. If there are unusually heavy or bright halos around the image, try using different mounting media such as glycerin or immersion oils of differing refractive index. Also, for optimum contrast, make sure that the green filter is in place.

4.0 Moving from Phase to Brightfield Viewing

The objectives in the Phase kit will also perform well as normal brightfield objectives. To change from phase to brightfield viewing, simply rotate the insert in the condenser turret to the "0" position and adjust the aperture iris for optimum contrast.

5.0 Summary

1. Replace the conventional objectives and condenser with the objectives and condenser from the Phase Kit.
2. Turn the Lamp on, turn the condenser insert to "0" and center a specimen over the light path.
3. Rotate the 10X objective into place and focus it on the specimen.
4. Rotate the condenser insert to "10"; replace the eyepiece with a centering telescope, and focus the telescope on the image of the bright and dark rings. If the dark ring is not in focus, use the focusing of the telescope to image it sharply. If the bright ring is not in focus, use the condenser focus adjustment to image it sharply. Use the centering screws in the condenser to place the bright ring over the dark one.
5. Replace the telescope with the conventional eyepiece and insert the green filter over the light path.